

**GDM-W220**

# SCREW-TYPE DOUGH SHEETER

**Dough sheeter with auto-recycling**



The fresh and recycled dough are evenly mixed together.

 **JAPAN  
QUALITY**



Compact design with  
automated off-cuts  
recycling



**TOA INDUSTRY CO., LTD.**

**Combination Example : Screw-type Dough Sheeter+Gyoza Machine TX-16**

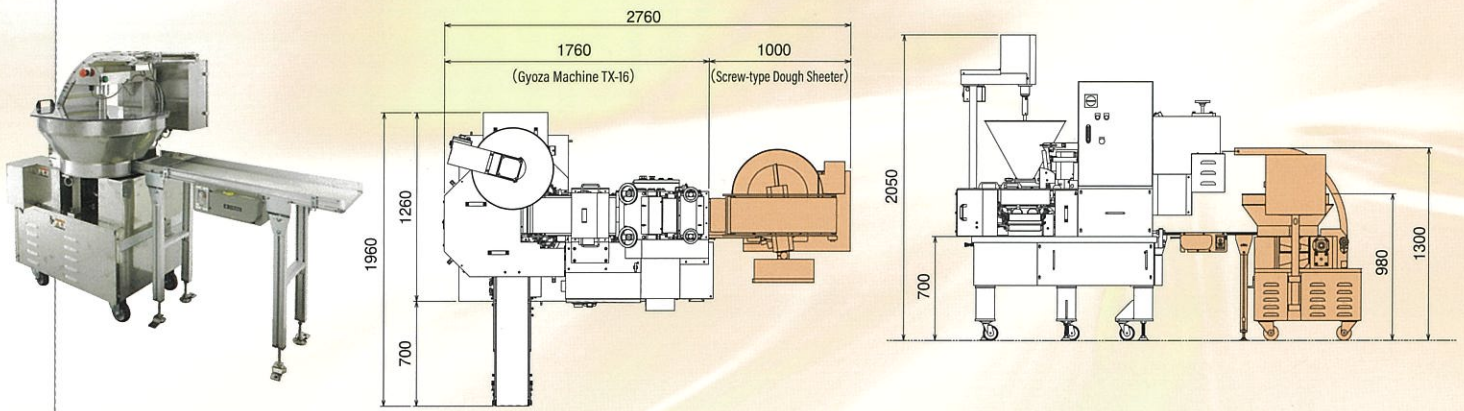

**Specifications**

Product Name	Screw-type Dough Sheeter	Roller Diameter	87.5mm
Model	GDM-W220	Dimensions	1000mm×890mm×1300mm ※Conveyor1000mm
Capacity	80kg/ hr	Power	3 phase 200V 2.10kW (Customizable for overseas voltages)
Hopper Capacity	30kg	Weight	380kg

※ It may vary depending on the specifications.

**This is a cost-effective entry model that can produce high quality dough sheet while reusing off-cuts.**



Fresh dough and off-cuts are evenly blended by the twin screw mechanism to produce a consistent dough sheet, which is then fed into the attached gyoza machine.

**Feel free to contact us for details.**



**TOA INDUSTRY CO.,LTD.**

260-1 Mikatahara Cho, Chuo Ku, Hamamatsu,  
Shizuoka Pref., Japan 433-8105



Tel : +81 53 436 2101

E-mail : infoen@toa-industry.co.jp

HP: www.toa-industry.co.jp

